



Fig. 453UG
GROOVED END DUCTILE IRON BODY CHECK VALVE

Features & Benefits

- UL listed. FM approved.
- Ductile Iron body with EPDM seat. Stainless steel plate.
- Grooves conform to ANSI / AWWA C-606 for steel pipe.
- Working pressure: 200 PSI, Cold water pressure(Max. temp 63°C).



Material List

Part Name	Material	ASTM SPEC.
Body	Ductile Iron	A536 65-45-12
Body Seal	EPDM	
Plate	Stainless Steel	ASTM A351.CF8
Spring	Stainless Steel	AISI 316
Hinge Pin	Stainless Steel	AISI 316
Washer	Teflon	
Thrust Washer	Teflon	
Plug	Mild Steel	A105-80
Square Plug	Mild Steel	A105-80
Packing	Buna"N"	

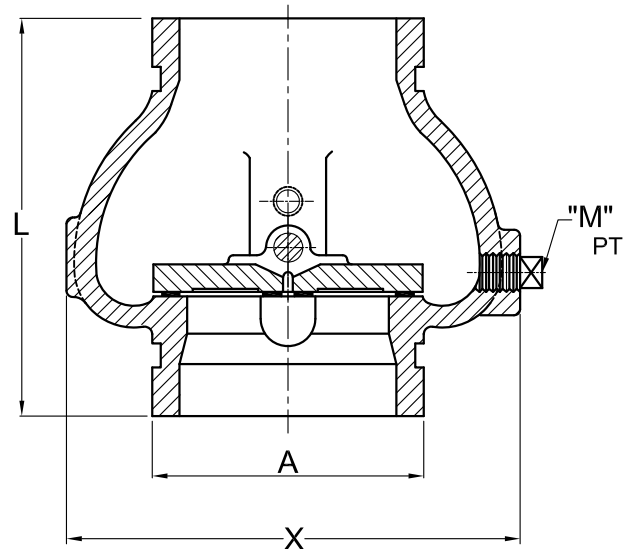

Dimensions (mm / Inch)

Valve Size	80mm / 3"		100mm / 4"		150mm / 6"		200mm / 8"	
	mm	Inch	mm	Inch	mm	Inch	mm	Inch
L	130.2	5-1/8	143	5-5/8	177.8	7	209.6	8-1/4
A	88.9	3-1/2	114.3	4-1/2	165.1	6-1/2	219.1	8-5/8
					168.3	6-5/8		
X	148.2	5-13/16	172	6-3/4	247.2	9-3/4	299.5	11-13/16
"M" PT		1/2"		1/2"		3/4"		3/4"

■ Note: Design and materials are subject to change without notice.