

CLASS 125 IRON BODY GLOBE VALVES

● Bolted Bonnet ● Renewable Seat and Disc ● Bronze Mounted

Working Pressure	125 Psi	
Test Pressure	Body	350 Psi
	Seat	200 Psi

Face-to-face Dimensions comply with the ANSI B16.10
End flanges conform to ANSI B16.1

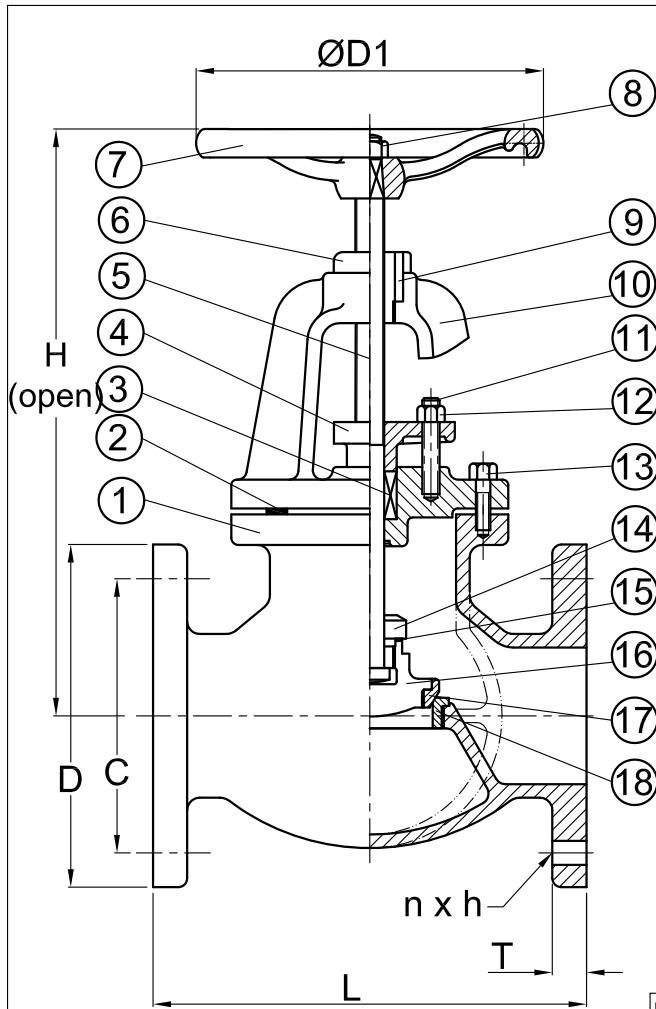
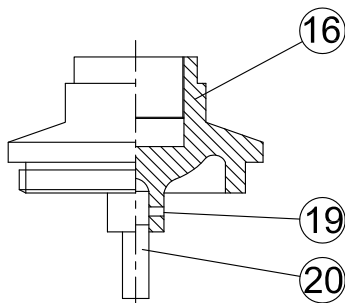

Fig: 755A



Size 5" to 12" Structure

MATERIAL LIST

Item No.	Part	Material	Specification
1 01	Body	Cast Iron	ASTM A126-B
2 14	Gasket	Non-Asbestos	
3 15	Packing	Non-Asbestos Packing	
4 06	Gland Flange	Ductile Iron	ASTM A536
5 12	Stem	Stainless Steel	SUS 410
6 09	Yoke Bush	Cast Bronze	ASTM B62
7 05	Hand Wheel	Cast Iron	ASTM A126-B
8 27	Nut	Steel	ASTM A307-A
9 28I	Socket Set Screw	Steel	ASTM A307-A
10 02	Bonnet	Cast Iron	ASTM A126-B
11 28F	Full Thread Bolt	Steel	ASTM A307-A
12 27	Nut	Steel	ASTM A307-A
13 28H	Hex.Head Bolt	Steel	ASTM A307-A
14 13	Lock Nut	Cast Bronze	ASTM B62
15 21	Stop Washer	Copper Plate	
16 03	Disc	Cast Iron	ASTM A126-B
17 08D	Body Seat Ring	Cast Bronze	ASTM B62
18 08B	Disc Seat Ring	Cast Bronze	ASTM B62
19 22T	Taper Pin	Steel	
20 22G	Guide Pin	Brass	ASTM B16

Dimensions

Unit:inch

Nominal Size	Dimensions							Net Wt. Lbs.
	H	L	C	D	D1	T	n x h	
2"	12 ¹³ / ₃₂	8	4 ³ / ₄	6	6 ⁵ / ₁₆	5/8	4x ³ / ₄	31.6
2-1/2"	13 ³⁹ / ₆₄	8 ¹ / ₂	5 ¹ / ₂	7	6 ⁵ / ₁₆	1 ¹ / ₁₆	4x ³ / ₄	42.4
3"	14 ¹³ / ₃₂	9 ¹ / ₂	6	7 ¹ / ₂	7 ¹ / ₁₆	3/4	4x ³ / ₄	48.9
4"	16 ⁷ / ₆₄	11 ¹ / ₂	7 ¹ / ₂	9	7 ⁷ / ₈	15/16	8x ³ / ₄	79.0
5"	18 ¹⁹ / ₆₄	13	8 ¹ / ₂	10	9 ⁷ / ₈	15/16	8x ⁷ / ₈	116.8
6"	20 ¹ / ₂	14	9 ¹ / ₂	11	11	1	8x ⁷ / ₈	156.5
8"	23 ¹³ / ₃₂	19 ¹ / ₂	11 ³ / ₄	13 ¹ / ₂	11 ¹³ / ₁₆	1 ¹ / ₈	8x ⁷ / ₈	251.3
10"	26 ²⁹ / ₃₂	24 ¹ / ₂	14 ¹ / ₄	16	14	1 ³ / ₁₆	12x1	425.5
12"	30 ¹³ / ₆₄	27 ¹ / ₂	17	19	15 ³ / ₄	1 ¹ / ₄	12x1	594.0

■ Note: Design and materials are subject to change without notice.

EVA EVER METAL INDUSTRY CO.,LTD