

CAST IRON "Y" STRAINERS

- 400 WOG Non-Shock(@ 100°F)
- 20 Mesh Stainless Steel Screen
- 250 PSI WSP
- Blow-off Plug Included
- Threaded NPT Ends
- NPT Ends:ANSI/ASME B1.20.1

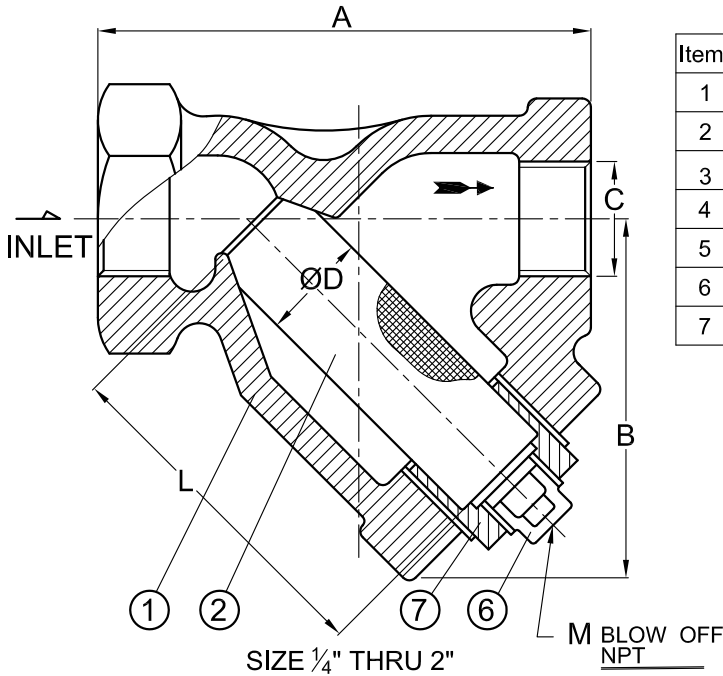

Fig: 756A(NPT)

MATERIAL LIST

Item	No.	Part	Material	Specification	Qty	Remarks
1	01	Body	Cast Iron	ASTM A126-B	1	
2	23	Screen	Stainless Steel	SUS 304	1	
3	14	Gasket	Non-Asbestos		1	
4	02	Cover	Cast Iron	ASTM A126-B	1	
5	28H	Hex.Head Bolt	Steel	ASTM A307-A	1Set	2-1/2",3"
6	28P	Plug	Malleable Iron	ASTM A197-B	1	
7	35	Cap	Ductile Iron	ASTM A536	1	

STANDARD SCREENS SUPPLIED

SIZE		SCREENS PERFORATION					OPEN AREA
		FOR STEAM		OPEN AREA	FOR LIQUID		
in	mm	in	mm		in	mm	
1/4"~2"	8~50	20 MESH STAINLESS STEEL					49%
2-1/2"~3"	65~80	3/64	1.2	33%	1/16	1.6	30%

Standard screens supplied are for liquid service, unless otherwise specified.
Options: Other perforations, meshes, and screen materials are available.

Cv & Weight

SIZE	1/4"~3/8"	1/2"	3/4"	1"	1-1/4"	1-1/2"	2"	2-1/2"	3"
mm	DN8~10	DN15	DN20	DN25	DN32	DN40	DN50	DN65	DN80
Cv	/	9.5	18.7	30	44.9	61	98	129.7	161.3
Wt.(lbs)	0.9	1.6	2.4	4.0	6.6	8.1	13	24	32

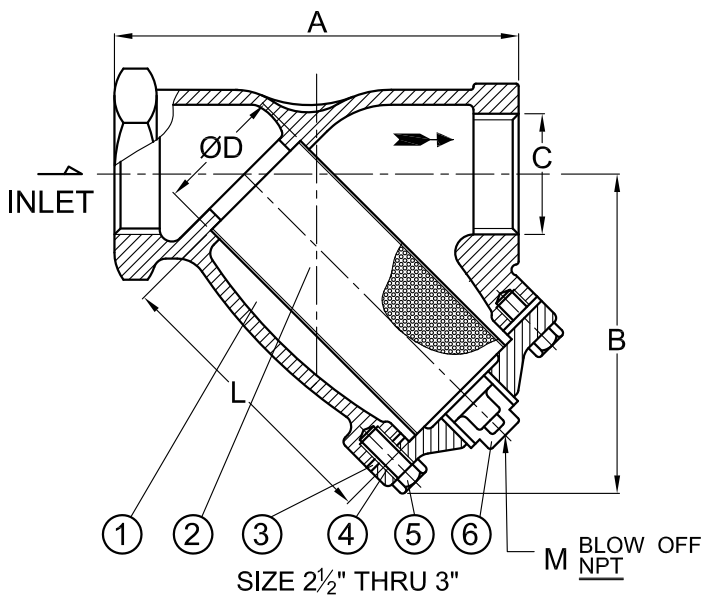

Fig: 756A(NPT)

Dimensions Unit: inch

Size	A	B	C	ØD	L	M(NPT)
1/4"	2 ⁵ / ₈	1 ¹⁵ / ₁₆	1/4"NPT	3 ³ / ₆₄	1 ⁵⁷ / ₆₄	1/4
3/8"	2 ⁵ / ₈	1 ¹⁵ / ₁₆	3/8"NPT	3 ³ / ₆₄	1 ⁵⁷ / ₆₄	1/4
1/2"	3 ¹³ / ₃₂	2 ⁷ / ₁₆	1/2"NPT	4 ⁵ / ₆₄	2 ¹³ / ₃₂	3/8
3/4"	4	2 ³ / ₄	3/4"NPT	5 ⁸ / ₆₄	2 ¹⁹ / ₃₂	1/2
1"	4 ⁵ / ₈	3 ¹¹ / ₃₂	1"NPT	1 ³ / ₁₆	3 ¹¹ / ₃₂	1/2
1 1/4"	5 ³ / ₈	3 ¹⁵ / ₁₆	1 1/4"NPT	1 ²⁹ / ₆₄	3 ¹⁵ / ₁₆	3/4
1 1/2"	6 ¹ / ₁₆	4 ⁹ / ₁₆	1 1/2"NPT	1 ²⁵ / ₃₂	4 ¹⁷ / ₃₂	3/4
2"	7 ¹ / ₂	5 ¹¹ / ₃₂	2"NPT	2 ²³ / ₆₄	5 ⁹ / ₃₂	1
2 1/2"	9	7 ³ / ₁₆	2 1/2"NPT	2 ⁴⁵ / ₆₄	6 ¹ / ₂	1 1/4
3"	10	7 ⁷ / ₈	3"NPT	3 ⁹ / ₃₂	7 ³ / ₃₂	1 1/4

■ Note: Design and materials are subject to change without notice.

EVA EVER METAL INDUSTRY CO.,LTD